

MOTORIZED SHUTTER KIT

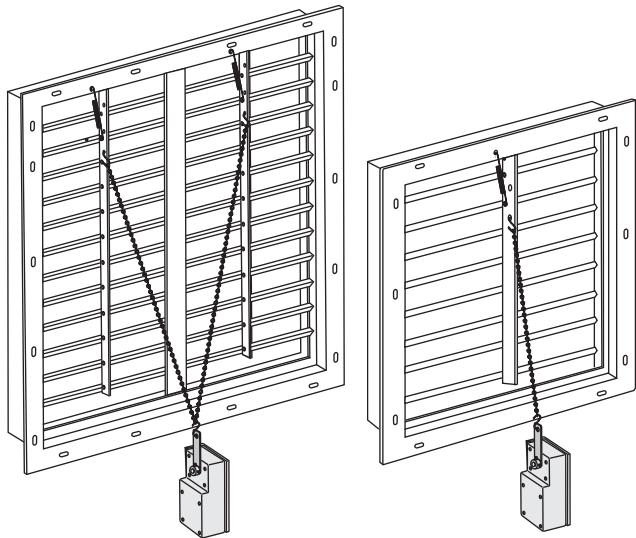

INSTALLATION

Please read over **ALL** instructions carefully before you begin. If you have any questions please call your local J&D reseller, or contact J&D Manufacturing at 1-800-998-2398.

The exact location of the motorizing shutter kit is critical for the correct operation of your motorized shutter. PLEASE READ AND FOLLOW DIRECTIONS CAREFULLY! Not following the mounting instructions will void the warranty.

With your shutter installed in the wall, locate the exact horizontal center of your shutter as illustrated below by the dashed line using a tape measure. Mark the center line on the wall directly below the shutter flange with a pencil. From this center line, measure 3/4" to the right of center as illustrated below and draw a line. This line will determine the left edge of your motor mount bracket. Now measure 2" down from the bottom edge of the lower shutter flange and mark with a pencil. This line will determine the top edge of your motor mount bracket.

Secure the motor mount bracket to your structure in this position using 3 fasteners (not included) appropriate for your building.

RECOMMENDED TOOLS FOR ASSEMBLY (NOT PROVIDED)

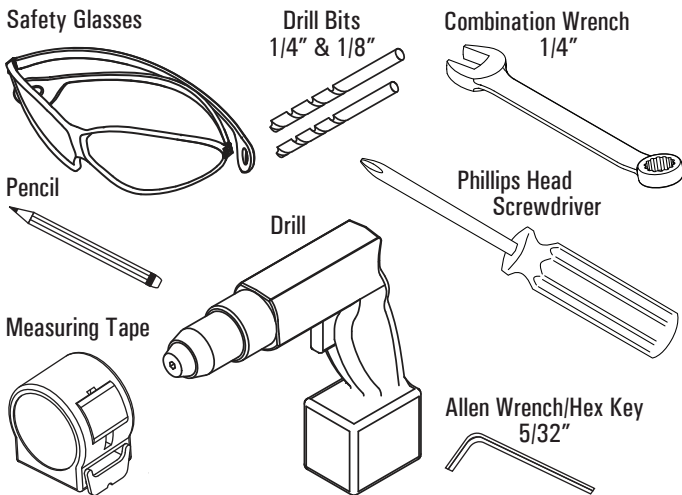

PARTS LEGEND

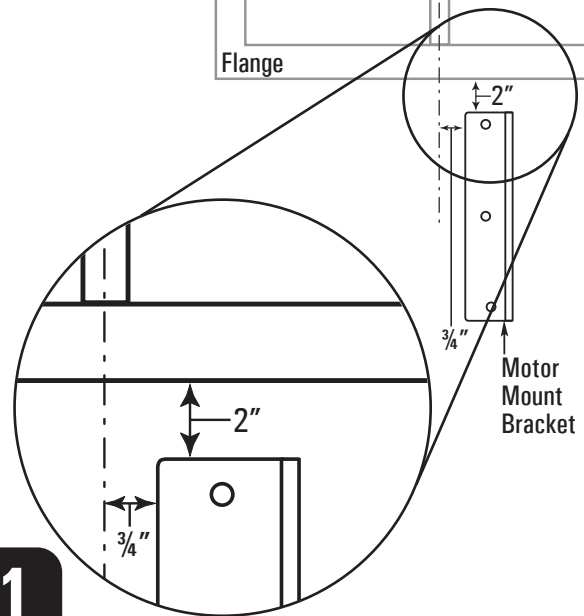
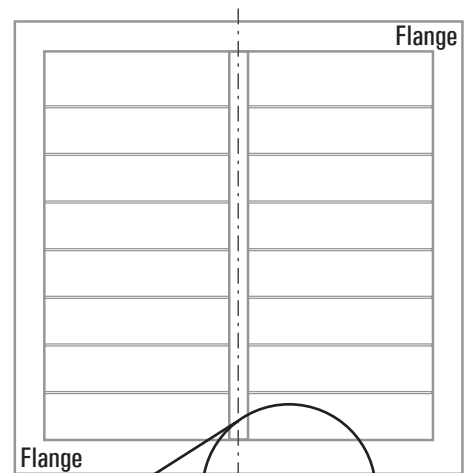
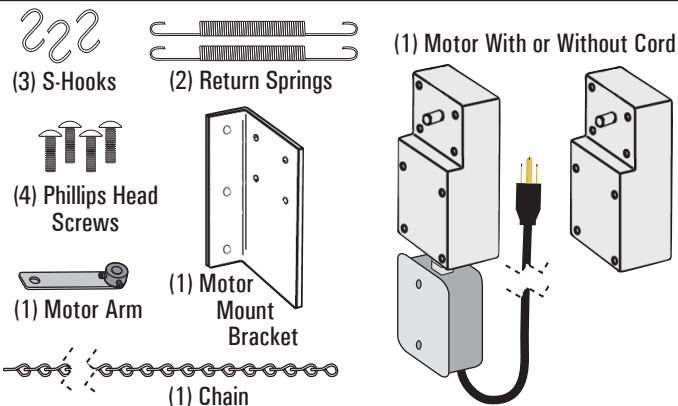

1

Secure the motor to the motor mount bracket using the (4) included Phillips Head Screws as shown.

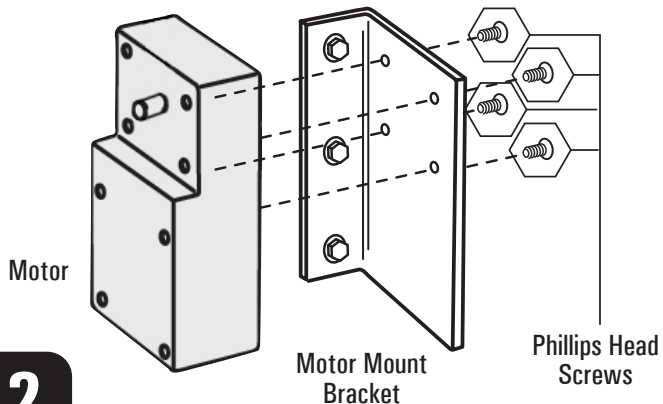

2

Attach motor arm to motor as shown, making sure to align the flat sides of the motor shaft with the screws, tighten screws with 5/32" Allen wrench/hex key. Then manually turn motor arm until it is straight up and down, as shown in illustration below. (When energized the motor arm and shaft only turn clockwise as viewed below.)

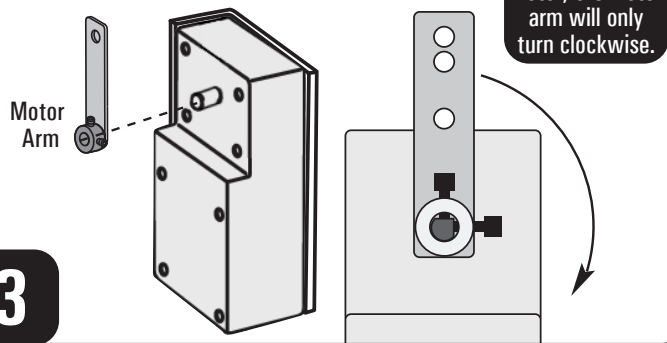

3

Locate the corner on your shutter where the outer flange meets the vertical tie bar(s) as shown below for a single panel or double panel shutter. Using a tape measure, mark a line 1/2" to the left of this corner and 1/4" up from the bottom of the upper shutter flange as shown. Drill a hole through the shutter flange using a 1/8" drill bit. Repeat on second panel for double panel shutters.

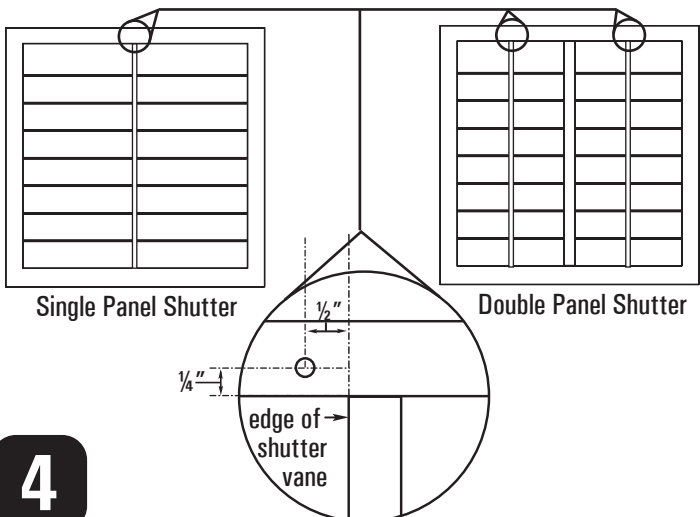

4

Hook one end of return spring into hole drilled in **Step 4**. Hook the other end of the return spring around the rivet and spacer for the 3rd louver from the top. For double panel shutter you will have to do this for each panel. See illustration.

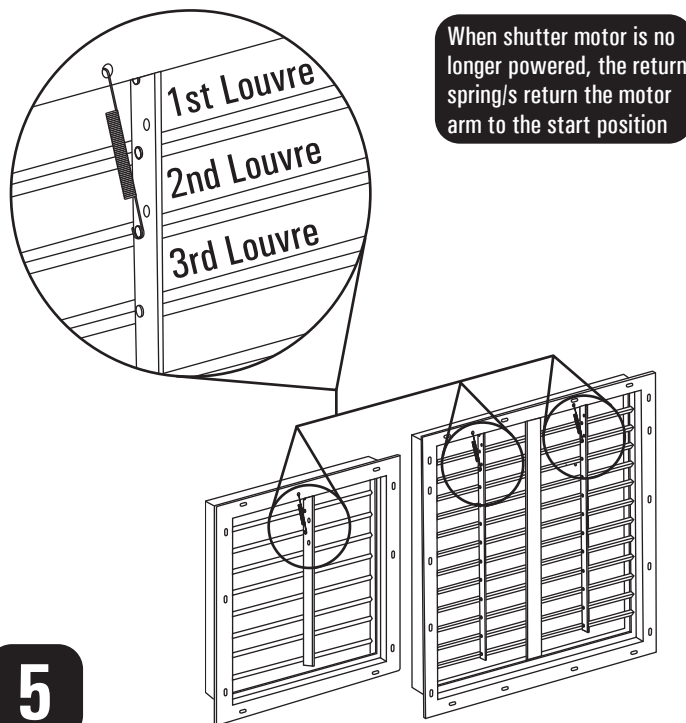

5

Insert an S-hook into the first available hole below the return spring in each tie bar so as not to interfere with the movement of the return spring. Attach the end of the chain to the S-hook in the tie bar.

Insert another S-hook in the top hole of the motor arm. Connect the chain to the motor arm S-hook so that it has a slight amount of slack.

For Single Panel – You may now trim the excess chain.

For Double Panel – Bring the loose end of the chain up and attach to the S-Hook on the second tie bar, leaving the same amount of slack as you did for the first connection. Trim excess chain.

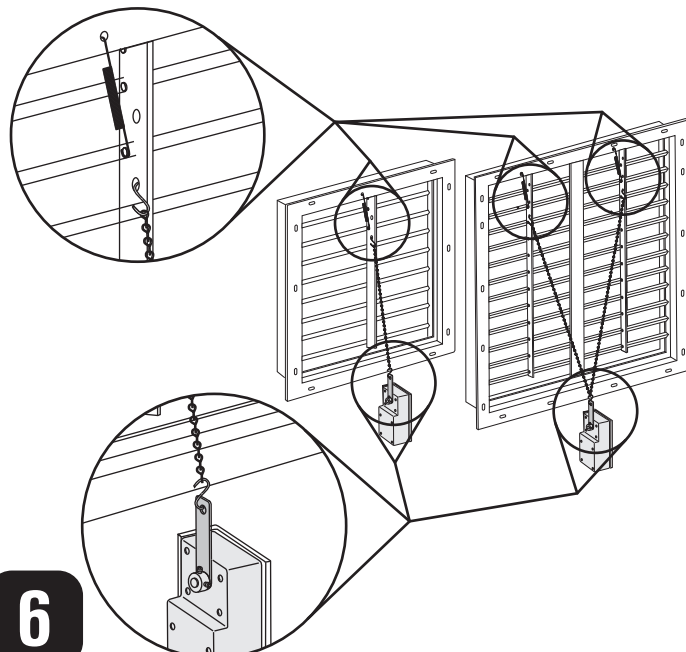

6



DISCONNECT POWER BEFORE INSTALLING OR SERVICING.



ALL ELECTRICAL WORK IS TO BE COMPLETED BY A LICENSED AND CERTIFIED ELECTRICIAN AND MEET NATIONAL (NEC), REGIONAL AND LOCAL ELECTRIC CODES.

IT IS THE RESPONSIBILITY OF THE CUSTOMER TO ENSURE THAT INSTALLATIONS MEET THIS AND ANY ADDITIONAL PROVIDED ELECTRICAL REQUIREMENTS.

J&D Manufacturing is not liable for issues arising from non-compliant wiring or installation by unqualified personnel.

PROVIDING POWER TO MOTOR

Instructions for corded models

- Provide a grounded outlet that meets or exceeds the load capability of your motor.
- Route cord to motor with drip loop and secure. Drip loop will drain accumulated moisture away from the motor.

Wiring instructions for non corded models

- Wiring should only be performed by a trained electrician to prevent injury or death.
- Install manual disconnect switch inside building adjacent to motor.
- Route wire to motor with drip loop and secure. Drip loop will drain accumulated moisture away from the motor.
- Configure to match supply voltage and wire according to motor nameplate.

Supply power to the shutter motor. Watch the movement of the shutter motor and shutter panel. Ensure panels do not bind during opening or closing.

Make sure that the motor arm is not stopped or hindered by the motor as shown below. If this happens, remove the power immediately and return the motor arm to the upright position. Reduce the slack on the chain and test again. When the chain is adjusted properly the motor arm is stopped when the shutter tie bar travel is halted by the shutter frame.

NOTE: As long as power is supplied to the motor it will actively apply force to the motor arm as it resists the pull from the return spring. The motor can remain energized for weeks with no ill effect to the motor. Once power is turned off the resistance of the return spring(s) will close the shutter and return the motor arm to the upright position.

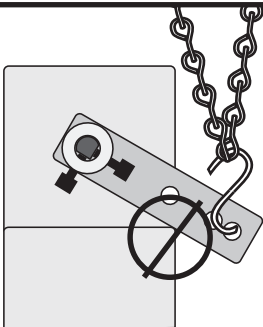

Do not allow the motor arm to be stopped or hindered by the motor body.

Shutter motor does not contain a limit switch.

7

TROUBLE SHOOTING GUIDE

Issue:

Arm keeps going around

The arm should only rotate about a quarter turn.

Possible Cause:

Lever arm was not straight up when attaching the chains to the shutter

OR

The chain is not tight enough when the shutter is in the closed position

Suggested Action/Solution:

- Disconnect power from the motor
- Reposition the lever arm so that it is straight up
- Reconnect the chain/s so that they are as short as possible without opening the shutter

Issue:

When the shutter is fully opened the motor does not shut off

There is no issue and the motor is functioning correctly.

The motor is designed to hold the shutter open when power is applied. It will go into a locked rotor state when the shutter is fully opened and will hold in that position until power is removed. Operating this way will not cause any damage to the motor. When correctly attached to the shutter the arm should only rotate about a quarter turn.

Issue:

Shutter does not fully close

When motor is not activated the shutter should rest with louvers fully closed

Possible Cause 1#:

Inadequate number of springs

Suggested Action/Solution 1#:

Install the recommended number of springs for your application. The spring/s will pull the shutters closed which moves the lever arm on the motor into the correct position.

Possible Cause 2#:

Inadequate tension on springs

Suggested Action/Solution 2#:

Disconnect power from the motor, reposition the lever arm so that it is straight up, and reposition springs to apply more pressure.